



## BULL DAWG SUV DOORS

5/18/2011

### The Perfect Companion for your Sport SUV

Another quality company by McLaughlin Manufacturing.

4737 Adams Road, Chattanooga, TN 37343

[www.bulldawgmfg.com](http://www.bulldawgmfg.com), 800-784-6478, 423-875-4040

## INSTALLATION INSTRUCTIONS

### FOR 1987 to 2006 YJ & TJ JEEP UPPER-HALF DOORS

(You can also view this installation sheet in color online at:

<http://www.bulldawgmfg.com/BullDawgmfginstall.pdf>)

To enjoy your "Bull Dawg" Doors for many years to come, proper installation is critical. Read all instructions carefully before beginning the installation process.

These single set of instructions cover the Wrangler YJ (1987 to 1995) and the TJ models (1997 to 2006). Several of the parts shown do not apply to all models but this is explained in the text.

**Warning:** This product is only designed for the Jeep Wrangler YJ & TJ built from 1987 to 2006 model years. This product is NOT to be installed on other vehicles. It is designed only to enhance the appearance, protect against undesirable weather conditions and aid in the security of the vehicle. It is not designed: to hold occupants inside the vehicle, to protect against foreign objects, or as protection in the event of an accident. **Occupants should wear seatbelts at all times.**

Because of the age and inconsistencies of the YJ models, slight adjustments to the Jeep windshield, lower metal doors or hardtop may be required.

**Bull Dawg Manufacturing will not be responsible for or accept back for restock doors that have been modified or damaged. Improper use of this product could cause serious injury to the vehicle occupants and damage to the doors.**

### "Standard" Installation Kit / Bill Of Materials

Part Name	Quantity	Location	Use
6" Bolts <b>TJ Only</b>	4	Box	To be used in conjunction with the Factory Door Inserts and Insert Nuts to secure the Upper-half door to the Lower-half factory steel door. These 6" bolts are to be used in the center and rear holes of the Upper-half Doors.
4" Bolts <b>TJ (2) - YJ (6)</b>	2/6	Box	To be used in conjunction with the Threaded Door Inserts to secure the upper-half door to the lower-half factory steel door. These 4" bolts are to be used in the front hole of each TJ door and all three holes in both the YJ doors.
Rubber Washers <b>TJ (8) - YJ (4)</b>	8/4	Box	Used to protect the texture from the bolt heads on all models and also to provide a spacer between the fiberglass door and Jeep door inserts on the BullDawg TJ model Only.
Steel Washers	6	Box	To be used between the bolt heads and rubber washers on all models(YJ & TJ).
Jeep Door Inserts "Threaded"	6	Box	Replaces the OEM inserts. Used in conjunction with bolts and washers to hold your new Upper-half door in place.
Windshield Frame Opening Gasket <b>YJ Only</b>	2	Box	Used to weather seal the forward edge of the YJ upper half doors against the windshield frame. <b>Not shown in photo below.</b> Approximate length 19 " each



Figure 1 – Standard Installation Kit(TJ or YJ)

**“Deluxe” Installation Kit / Bill Of Materials**

Part Name	Quantity	Location	Use
6" Bolts <b>TJ Only</b>	2	Box	To be used in conjunction with the Factory Door Inserts and Insert Nuts to secure the Upper-half door to the Lower-half factory steel door. These 6" bolts are to be used in the center and rear holes of the Upper-half Doors.
4" Bolts <b>TJ (2) - YJ (6)</b>	2/6	Box	To be used in conjunction with the Threaded Door Inserts to secure the upper-half door to the lower-half factory steel door. These 4" bolts are to be used in the front hole of each TJ door and all three holes in both the YJ doors.
Rubber Washers <b>TJ (8) – YJ (4)</b>	8/4	Box	Used to protect the texture from the bolt heads on all models and also to provide a spacer between the fiberglass door and Jeep door inserts on the BullDawg TJ model Only.
Steel Washers	6	Box	To be used between the bolt heads and rubber washers on all models(YJ & TJ).
Jeep Door Inserts "Threaded"	6	Box	Replaces the OEM inserts. Used in conjunction with bolts and washers to hold your new Upper-half door in place.
Windshield Frame Opening Gasket <b>YJ Only</b>	2	Box	Used to weather seal the forward edge of the YJ upper half doors against the windshield frame. <b>Not shown in photo below.</b> Approximate length 19 " each



Optional Deluxe (Locking) Half Door Installation Kit\*

**Note: These instructions apply to both kits. With the Deluxe kit no screw driver is required.**

**Measure Windshield Distance**

The following instructions apply to Jeeps whose steel doors and body are properly aligned within factory specifications. In most cases the windshield will not require adjusting for your Bull Dog Doors to fit correctly. Before installing your new Upper Doors, check the windshield measurement. The distance from the top lid of the windshield to the top outer edge of the tub should be **75 1/8"** on both sides of the vehicle. If the angle needs to be adjusted, we recommend using an authorized Jeep dealer.

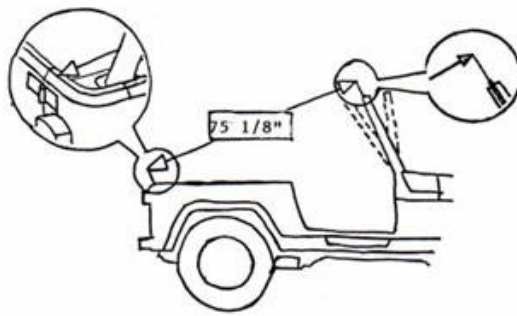

**Figure 2 – Windshield distance**

## Instructions

1. Remove the soft upper half doors. Remove the factory installed Jeep door inserts by using a large flat-head screwdriver and gently prying them up. (See Figure 2)



**Figure 2.**

Once started, the door inserts can then easily be removed by hand. There should be six (6) inserts in all, three (3) per side.

2. Install the six (6) "threaded door Insert Nuts" (*provided with the installation kit*) into the lower half doors. Be careful not to install the inserts backwards. They should sit down flush with the surface of the door. When installing the inserts, twist and push down at the same time and they will lock into place. If you try to force them straight down or hammer them into place you run the risk of breaking the tabs which are intended to hold them in place.



**Figure 3.**

**SPECIAL YJ NOTE: Instructions 3, 4, and 5 are modified as follows: The YJ only uses 4**

## inch bolts along with the steel washers

- 3. Assemble either the two 6" bolts(TJ) and/or two of the 4" bolts(YJ) with washers.** Install one steel washer and then one rubber washer onto each of these bolts.
- 4. TJ Doors Only:** Insert the two 6" bolts assembled with both a steel washer and a rubber washer into the center and rear holes of each upper-half door. Then install a 4" bolt with a hard steel washer only into the front holes of each door as shown in figure 4 below. Next, slide another rubber washer onto the bottom of each of the 6" bolts (figure 5 below). This washer will serve as a spacer between the upper and lower door halves. Push the rubber washers onto the bolts until they make contact with the bottom of the armrest. (Note; there are no rubber washers being used either on the top or bottom of the two 4" forward bolts)

Note: The rubber washers that go between the two door halves(as noted above) only pertains to the "BullDawg" brand of TJ upper doors. If you own a set of BullDawg YJ upper doors or an altogether different brand of upper doors then the rubber spacer between the two door halves is not needed altogether.

**YJ Doors Only:** Insert two 4" bolts assembled with both a steel washer and a rubber washer into the center and rear holes of each upper-half door. Then install another 4" bolt with a hard steel washer only into the front holes of each of the upper door halves. The two pictures below are of a TJ door and do not apply to the YJ.

Note: The BullDawg YJ doors do not require rubber washers to be placed between the fiberglass upper doors and the lower metal doors.

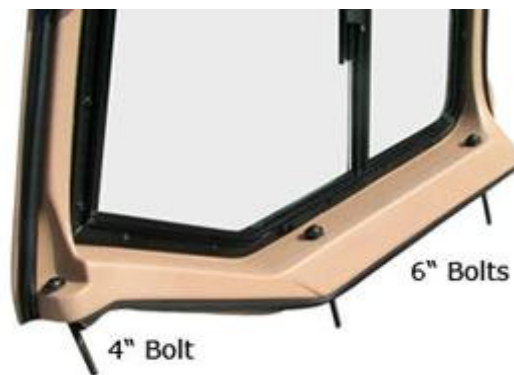

**Figure 4 – Proper Placement of Bolts and Washers**



**Figure 5**

**Note: The rubber washers**

7. With all 3 bolts in their proper holes, place the fiberglass Upper-Half Door over the metal Lower-Half Door aligning the bolts over the Threaded Jeep Door Inserts and lower the door into place. Use a large flat-head screwdriver to tighten the bolts. DO NOT OVER TIGHTEN.
8. The YJ upper half doors may require the use of an additional gasket which is provided in the installation kit. If there is a gap between the front edge of the door and the windshield frame fill the gap using the extra gasket provided. Peel away several inches of the paper protecting the self adhesive surface. Position the gasket even with the bottom of the windshield frame and aligned with the outside of the frame. Pull the remainder of the paper and continue to position as described. (See figure 6)



**Figure 6**

9. Complete a door alignment check. Slowly close the door to make sure that it fits correctly. The door should close without the Upper-Half Door hitting the Hardtop opening and the door gaskets should fit firmly in place. If it does not you should try the following:
  - a) Make sure the Upper-Half Door is installed correctly to the Lower-Half door.
  - b) Adjusting the Hard or Soft-top using the proper owners' manual.
  - c) Align your metal Lower-Half Doors. See your Jeep Owners Manual to properly align your doors.

It is the owners' responsibility to insure proper installation and perform monthly maintenance checks of fasteners. Doing so will assure safe operation and long life of your upper hard doors.

### ***FAQ AND HELPFUL HINTS***

1. **What if the gasketing comes loose?** Clean both surfaces then apply a small amount of super glue and reapply the gasket.
2. **How do I maintain and protect my new fiberglass Doors?** Wash and clean using a soft cloth and a non-abrasive soap and water. To maintain a shine, simply coat the doors with Bull Dawg UV

Sealer Glaze (Found it the parts section) Or an Armour-All type product. Do not attempt to wax the doors with a normal car paste wax.

### **Bull Dawg Top/Door UV Sealer Glaze 12 oz**



Although the surface of your Jeep Doors are made with a durable gelcoat finish, it still needs to be protected with some kind of a special conditioner periodically. Neglected gelcoat finishes tend to dry out and fade over time from the sun's harmful UV rays. In order to prevent this, we recommend using our own brand of special UV sealer that is especially designed to protect and beautify your Jeep Door's gelcoat finish for years to come. It's quick and easy to use formula shines and protects in one easy to apply step. Just wipe it on and leave it on, no buffing required.

DO NOT use automotive liquid or paste wax on your Bull Dawg doors. This will only cause an undesirable build up of wax, which is very difficult to remove from the gelcoated texture

- 3. What if my windows are difficult to slide open or closed?** Apply a small amount of liquid spray silicone, PTFE, or other lubricant in the window channels. Slide the windows back and forth a few times to evenly distribute the lubricant and then wipe off the excess.
- 4. Reinstalling the soft upper doors:** When reinstalling the soft upper doors, it is necessary to replace the original Jeep door inserts in order to avoid damaging the threaded inserts provided with your fiberglass upper doors.

## **ENJOY YOUR NEW UPPER-HALF DOORS!!**

### **Customer Service or Technical Questions**

If you have any questions please contact your dealer or Bull Dawg's customer service department at 800-784-6478. Bull Dawg's hours of operation are Monday through Friday 8am to 4pm Eastern Standard Time. You may also find additional information or you may contact us electronically from our website at

[www.bulldawgmfg.com](http://www.bulldawgmfg.com)